

**GUIDELINES FOR IMPLEMENTATION
SYNCHRONIZATION OF THE DIGITAL
TELECOMMUNICATION NETWORK**

FOREWORD

This **Guidelines for implementation, Synchronization of the digital telecommunication network** contains clarifications and recommended option selections for ITU-T Recommendations related to synchronization and also some additional recommendations related to synchronization and not covered by the ITU-T Recommendations. The aim of this document is to ensure the due synchronization of the digital telecommunications networks in Finland. This version covers aspects of PDH and SDH synchronization, transfer and distribution of synchronization and a new clause 9 Synchronization in packet networks. The new clause covers mainly issues related to carrying synchronization via packet networks and synchronous Ethernet. This GFI contains also a clause 10 covering some first issues for time/phase synchronization in packet networks. In the future this GFI will be updated to cover packet network synchronization issues more deeply when these issues are progressed in international standardization.

The overall technical provisions for synchronization are given in FICORA Technical regulation 26 D/2008 M. This guidance document gives more detailed recommendations on the use of standards and on the implementation issues.

This GFI does not cover all issues related to networks which serve single frequency transmissions (e.g. DVB). These networks may have different technical requirements.

This guideline document has been prepared by the members of the national standardization group for transmission systems.

Contents

FOREWORD	1
REFERENCES	3
ABBREVIATIONS	4
1 SYNCHRONIZATION NETWORK ARCHITECTURE	4
1.1 National synchronization network	4
1.1.1 Synchronous method	4
1.1.2 Pseudo-synchronous method	6
2 CONTROL OF JITTER AND WANDER WITHIN SYNCHRONIZATION NETWORKS	7
3 TIMING CHARACTERISTICS OF SLAVE CLOCKS	7
4 TIMING CHARACTERISTICS OF PRIMARY REFERENCE CLOCKS	7
5 OPERATION AND MAINTENANCE OF SYNCHRONIZATION NETWORKS	7
5.1 Management of synchronization trails	7
5.2 Maintenance of synchronization trails	7
5.3 Performance monitoring	8
6 PLANNING OF SYNCHRONIZATION NETWORKS	8
6.1 Planning principles	8
6.2 SDH/PDH	9
6.3 OTN	11
6.4 Packet networks	12
7 SEC AS NODE CLOCK	13
8 SYNCHRONIZING THE SDH/PDH TRAFFIC NETWORKS	14
9 SYNCHRONIZATION IN PACKET NETWORKS	14
9.1 TDM timing requirements	14
9.2 Synchronization Network Engineering in Packet Networks	15
9.3 Reference Timing Signal Distribution over Packet Networks	15
9.3.1 Plesiochronous and Network Synchronous Methods	15
9.3.2 Packet based Methods	16
9.4 Timing Recovery for Constant Bit Rate services transported over Packet Networks	17
9.5 Recommendations for the synchronisation in packet networks	20
10 TIME/PHASE SYNCHRONIZATION IN PACKET NETWORKS	20

REFERENCES

ITU-T G.810	Definitions and terminology for synchronization networks
ITU-T G.803	Architecture of transport networks based on the synchronous digital hierarchy (SDH)
ITU-T G.823	The control of jitter and wander within digital networks which are based on the 2048 kbit/s hierarchy
ITU-T G.824	The control of jitter and wander within digital networks which are based on the 1544 kbit/s hierarchy
ITU-T G.825	The control of jitter and wander within digital networks which are based on the synchronous digital hierarchy (SDH)
ITU-T G.812	Timing requirements of slave clocks suitable for use as node clocks in synchronization networks
ITU-T G.813	Timing characteristics of SDH equipment slave clocks (SEC)
ITU-T G.811	Timing characteristics of primary reference clocks
ITU-T G.8251	The control of jitter and wander within the Optical Transport Network (OTN)
ITU-T G.8260	Definitions and terminology for synchronization in packet networks
ITU-T G.8261	Timing and synchronization aspects in packet networks
ITU-T G.8262	Timing characteristics of synchronous Ethernet Equipment Slave Clock (EEC)
ITU-T G.8264	Distribution of timing through packet networks
ITU-T G.8265	Architecture and requirements for packet based frequency delivery
ITU-T G.8265.1	Precision time protocol telecom profile for frequency synchronization

ABBREVIATIONS

CBR	Constant Bit Rate
CE	Customer Equipment
CES	Circuit Emulation Services
EEC	Ethernet Equipment slave Clock
GPS	Global Positioning System
GSM	Global System for Mobile Communications
IWF	InterWorking Function
NE	Network Element
NTP	Network Time Protocol
ODUk	Optical channel Data Unit - k
OTN	Optical Transport Network
PDH	Plesiochronous Digital Hierarchy
PRC	Primary Reference Clock
PSTN	Public Switched Telephone Network
SASE	Stand Alone Synchronization Equipment
SDH	Synchronous Digital Hierarchy
SEC	SDH Equipment Clock
SRTS	Synchronous Residual Time Stamp
SSM	Synchronization Status Message
SSU	Synchronization Supply Unit
STM-N	Synchronous Transport Module N
TDM	Time Division Multiplex
WCDMA	Wideband Code Division Multiple Access

1 SYNCHRONIZATION NETWORK ARCHITECTURE

General requirements for the synchronization network architecture are specified in the ITU-T Recommendations G.803, G.8251, G.8260, G.8261 and G.8265. Both synchronous and pseudo-synchronous modes can be used in the national network.

1.1 National synchronization network

Additional information concerning the national synchronization network is given below.

The national telecommunication network consists of networks owned by separate operators.

Digital exchanges, SDH cross connects and stand alone synchronization equipment (SASE) can serve as nodes of the synchronization network called Synchronization Supply Unit (SSU). The distribution of timing can be done by using 2.048 MHz or 2.048 Mbit/s or STM-N signal. Each operator network operates synchronously. Both synchronous and pseudo-synchronous methods are possible between the networks of separate operators.

1.1.1 Synchronous method

The principle of the synchronization network structure in the case of synchronous method is shown in figure 1.

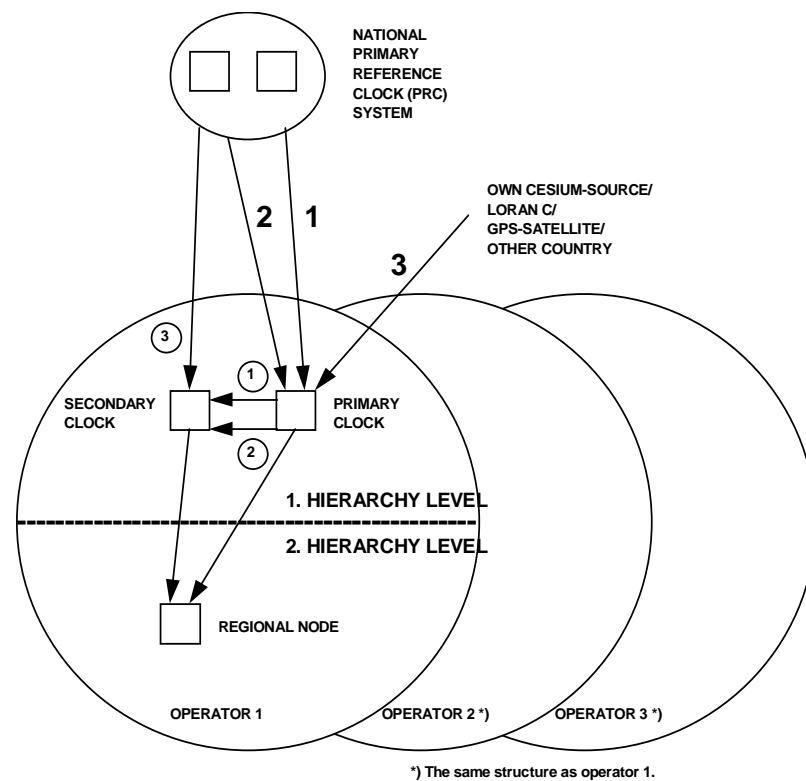

Figure 1. National synchronization network structure in case of synchronous method

The national synchronization network is based on the national primary reference clock (PRC) system. The system consists of two totally separate reference clocks, which fulfill the requirements of ITU-T Recommendation G.811. The synchronization signal of the operator network is derived from the national PRC system.

The owner of the national PRC system and the other operators agree the principles which are to be applied in the maintenance of the system and in the sharing of the costs caused by it. For the time being the owner of the national PRC system is TeliaSonera Finland. The PRC system consists of two separate clocks, one with two cesium sources and a SASE and the other with one cesium source and a SASE. The SASEs correspond with the primary and secondary clocks in TeliaSonera's network (see figure 1).

The synchronization network of the operator is connected to the PRC system using the principle that the primary clock of the network derives the primary and secondary synchronization signal from different outputs of the PRC system and uses physically separated transmission systems for the transfer of the signal (1 and 2 in Figure 1).

The secondary clock of the network is a synchronization node, which derives its primary and secondary synchronization signals from the primary clock of the network. The two

synchronization signals are transferred via independent transmission systems (① and ② in Figure 1).

The primary clock of the network may have a third alternative synchronization source, e.g. own cesium reference, GPS satellite connection, Loran C radio network connection or connection to the network of a foreign operator. In failure situations the networks may then function temporarily pseudo-synchronously (3 in Figure 1).

A connection to the national PRC system is defined as the third alternative synchronization source for the secondary clock of the network (③ in Figure 1).

The lower level nodes in the synchronization networks shall have access to the primary and the secondary clock of the network (regional node in Figure 1).

Each operator can define if the telephone, mobile, data etc. networks are separate master-slave systems which have on the highest level connections to the primary and secondary clocks of the network or they form together one master-slave system. It is recommended that the latter principle is used i.e. the nodes of the separate networks are synchronized (from the synchronization network) mainly in the regional level.

All operators may not have direct connections from the national PRC system. Transfer of the synchronization signals via a network owned by another operator may thus be necessary. In such a case the parties agree the related technical and economical facts. The synchronization trails starting from the PRC system shall be checked for conformity with the standards (refer to chapter 6).

In the networks of small regional operators and service providers the above described structure may not be required. They may derive the synchronization signals from another operator's synchronization network. In such a case the parties agree the related technical and economical facts. The synchronization networks of the parties as a whole shall meet the above-described structure and other related standards.

It is important that the transfer of synchronization between the networks of separate operators is configured in one direction only. It shall not be fed backwards at any point. Otherwise there is a danger of timing loop.

Each operator and service provider is responsible for proper planning of the synchronization within its own network.

1.1.2 Pseudo-synchronous method

The principles defined in the synchronous method are applied also in case of an operator using the pseudo-synchronous method. The only difference is that the equivalent of the national PRC system must in this case be operated and maintained by the operator itself.

2 CONTROL OF JITTER AND WANDER WITHIN SYNCHRONIZATION NETWORKS

The specifications for jitter and wander within synchronization networks are contained in the ITU-T Recommendations G.823, G.825 and G.8261.

3 TIMING CHARACTERISTICS OF SLAVE CLOCKS

The specifications for timing characteristics of slave clocks are contained in the ITU-T Recommendations G.812, G.813 and G.8262.

4 TIMING CHARACTERISTICS OF PRIMARY REFERENCE CLOCKS

The specifications for timing characteristics of primary reference clocks are contained in the ITU-T Recommendation G.811.

5 OPERATION AND MAINTENANCE OF SYNCHRONIZATION NETWORKS

5.1 Management of synchronization trails

From all the synchronization trails entering a node it is possible to create and delete synchronization trails with a software command. Furthermore it is possible to change the priority of synchronization trails.

The operational mode of the synchronization node is set automatically or manually.

The existing synchronization trails and their priorities can be listed with a software command.

Management operations to the synchronization trails are accomplished without interfering operation of normal traffic handling.

5.2 Maintenance of synchronization trails

Synchronization trails monitoring is included in the alarm system. Alarms are generated at least in the following events:

- change to the stand-by clock unit
- change of synchronization trail
- loss of synchronization trail

The event of the recovery should also be recorded.

If all the synchronization trails entering a node are lost the node shall operate in hold-over mode.

5.3 Performance monitoring

Some types of synchronization equipment (e.g. SASE) are able to online measure the wander of their input signals. By setting thresholds a deteriorated synchronization trail can be detected and disabled as a reference. This feature may also be used to monitor the synchronism of some important NE in the node by measuring its output signal. The measurement results (either threshold crossing events or complete measurement data files) may be collected by the management system.

6 PLANNING OF SYNCHRONIZATION NETWORKS

6.1 Planning principles

The planning of synchronization in the networks of the operators is fully independent to each other with the exception of one operator providing another operator with synchronization signals (refer to chapter 1.1.1).

The architecture of the synchronization network of an operator shall be in accordance with the ITU-T Recommendation G.803.

A general procedure in planning the synchronization network may be as follows.

If the synchronous method is used:

- Find out the connections to the national PRC-system
- Plan the locations for SSUs
- Plan the synchronization trails

If the pseudo-synchronous method is used:

- Plan the PRC system
- Plan the locations for SSUs
- Plan the synchronization trails

When planning the placing for SSUs the importance of the node locations for the traffic networks to be synchronized and the synchronization network itself is considered. The maximum number of SEC clocks between two SSUs has also to be taken into account (refer to figure 3).

When planning the synchronization trails first the transmission systems for the transfer of synchronization are selected. Secondly the timing configuration of the selected systems is planned in detail.

After the detailed planning for the synchronization of a sub-network is finished the presence of potential timing loops is checked. A simple method for that is to follow through all physical loops (clockwise and counter-clockwise) and make sure that the reference signal loop is not closed. The priorities of the references are ignored in the checking procedure.

6.2 SDH/PDH

The clock reference signals are distributed between levels of the hierarchy via distribution trails offered by normal SDH or PDH transmission systems. No special transport network for the distribution of synchronizing signals is used. It shall be noted that a 2.048 Mbit/s signal crossing SDH network shall not be used for timing distribution in the synchronization network.

The main points of the synchronization network architecture are explained next.

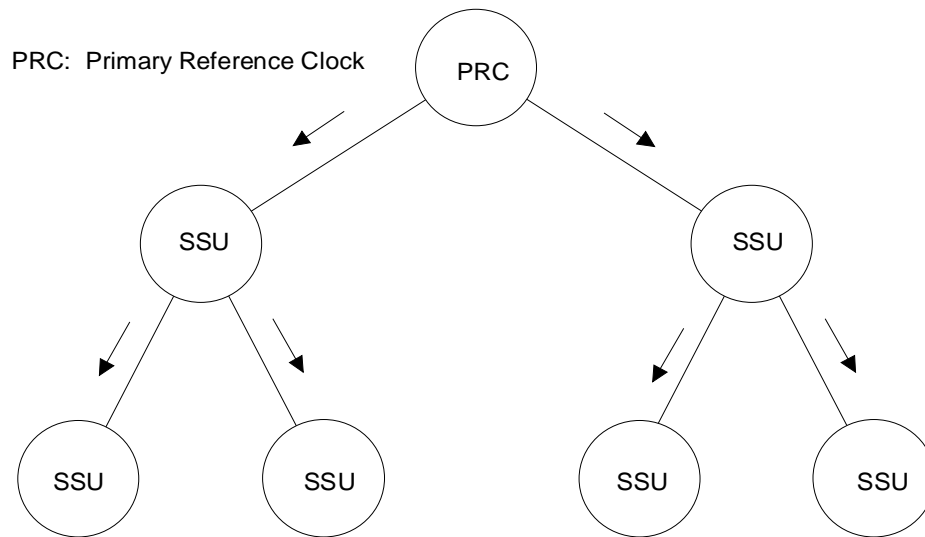

Figure 2. Synchronization network topology

The topology of the hierarchical synchronization network is tree-like as shown in figure 2.

The synchronization architecture requires that the timing of all network element clocks are traceable to a PRC and hence the principal structure is the synchronization network reference chain as shown in figure 3. Timing is distributed via master-slave synchronization from the PRC to all clocks in the chain.

To ensure the correct operation of the synchronization network it is important that clocks of lower hierarchical level only accept timing from clocks of the same or higher hierarchical level and that timing loops are avoided.

The distribution network shall be designed so that the requirements for the hierarchical network reference chain (described below) will be met even under fault conditions.

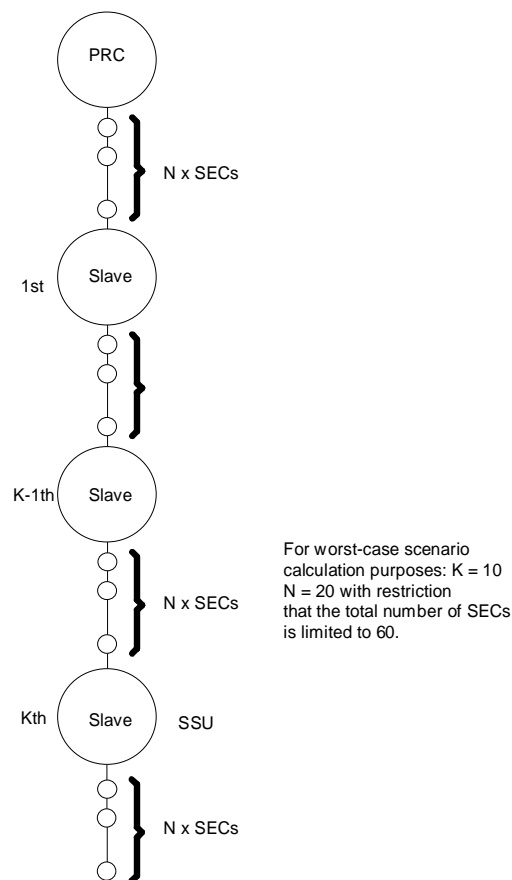

Figure 3. Synchronization network reference chain

In general, the quality of timing will deteriorate as the number of synchronized clocks in tandem increases and hence for practical synchronization network design, the number of network elements in tandem should be minimized. Based on theoretical calculations it is recommended that the longest chain should not exceed 10 SSUs and 20 SECs interconnecting any SSUs with restriction that the total number of SECs is limited to 60 (refer to figure 3).

It is preferable that all SSUs and SECs are able to recover timing from at least two synchronization trails. The slave clock shall reconfigure to recover timing from an alternative trail if the original trail fails. Where possible synchronization trails should be provided over diversely routed paths.

In the event of a failure of synchronization distribution, all network elements will seek to recover timing from the highest hierarchical level clock source available. To effect this, both SSUs and SECs may have to reconfigure and recover timing from one of their alternate synchronization trails.

SSM and squelching may be used on SDH trails for correct reference transfer between the SSUs. The use of SSM also makes it possible to recover timing for the SEC clocks in the chain from the opposite direction if the signal in the original direction fails.

6.3 OTN

The Optical Transport Network (OTN) physical layer is not required to transport network synchronization. However, the introduction of the OTN changes the position of an STM-N signal in the sense that it can now be a client signal within the OTN layer network.

This might affect the synchronization network architecture, since the STM-N signal is currently used as a carrier for synchronization information.

Provisional synchronization reference model has still 1 PRC and 10 SSUs, but the inter-SSU connections are now presumed to be over the OTN network. For a synchronous Ethernet client, the SECs are replaced by EECs.

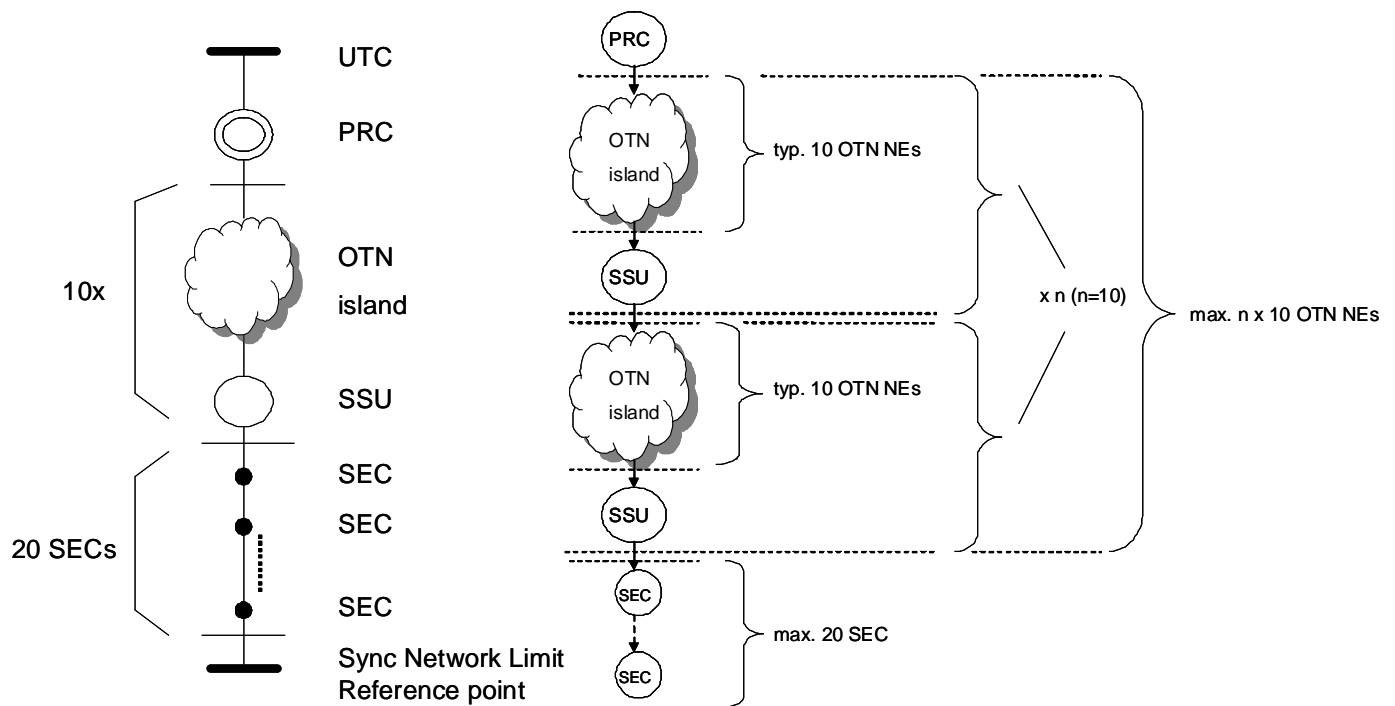

Figure 4. Synchronization reference model with OTNs

The composition of each OTN island in the provisional model is assumed to consist of 1 OTN network element that performs the mapping operation and 9 other OTN network elements that perform multiplexing operations of ODUks.

In the model there is one OTN island between each SSU pair, but another distribution is also allowed. For example, five inter-SSU connections may have two OTN islands each while the other interconnections make use of the STM-N physical layer. Also, the number of

multiplexing/mapping network elements may be freely re-divided over the OTN islands, to create some "large" and some "small" OTN islands.

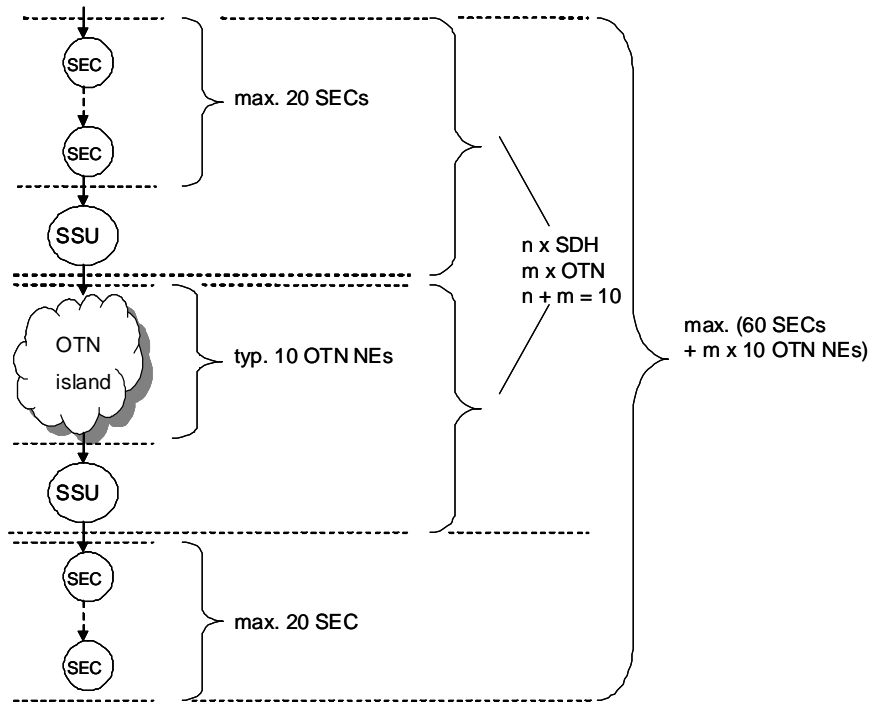

Figure 5. Synchronization reference model with OTNs and STM-Ns

6.4 Packet networks

With the introduction of synchronization in Packet Switched Networks (PSN), the packet switched NEs supporting Synchronous Ethernet must be able to transfer timing information and interwork with SDH NEs (e.g., containing SEC). The packet switched network elements containing EEC must be able to provide synchronization lines between PRC and SSUs and supply synchronization to time sensitive applications. The new timing links via packet switched networks must be in line with existing SDH timing links for inter-operability with the synchronization network. Figure 6 a shows two synchronization chains, one formed by SDH NE (circles with "S") and the other formed by packet switched NEs using Synchronous Ethernet interfaces (circles with E).

Hybrid NEs that offer both STM-N interfaces with associated SDH-VC cross connect functions and Synchronous Ethernet interfaces (ETY) with associated packet switching. It should be possible to use such hybrid NEs at any place in synchronization chains. An example is illustrated in Figure 6 b. The upper hybrid NE (circle with H) uses an STM-N interface at the ingress and an ETY interface at the egress. The lower hybrid NE uses an ETY interface at the ingress and an STM-N interface at the egress. Timing is transferred from STM-N to ETY and from ETY to STM-N, respectively.

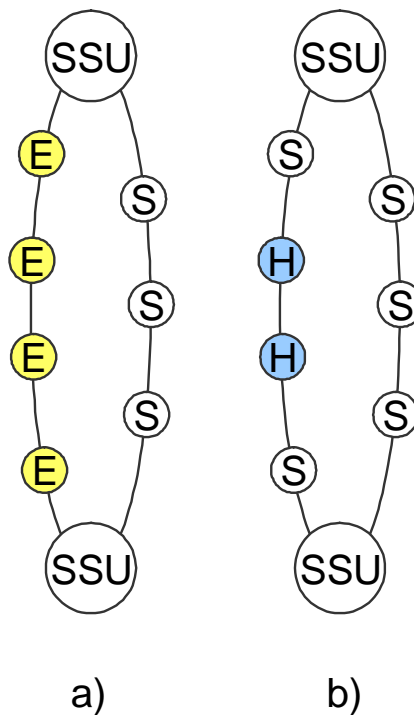

Figure 6 - Synchronization chains implemented with different types of NEs.

Another important aspect to consider is related to the proper handling of the SSM in the synchronization chain. The main role of SSM in Synchronous Ethernet networks, similarly to the case of SDH networks, is then to support in the design of the synchronization networks in order to properly handle fault conditions.

When designing the synchronization network, it should be provided that the SSM is processed in every network element that can alter the timing flow (e.g., due to internal clock entering the holdover state). It should also be avoided that timing is distributed with good quality, but SSM is not supported.

The network models and the related network limits are defined separately for the case of Synchronous Ethernet (EEC interface) and in case of the packet based clocks (PNC interface).

7 SEC AS NODE CLOCK

As shown in figure 3 the synchronization is transported via chains of cascaded SEC clocks. E.g. for economic reasons some nodes may be configured without SSU. The major SDH NE of the node (which implements an SEC) may be used as the node clock. The output of this major SDH NE is distributed via STM-N interfaces to other SDH NEs and via 2.048 MHz or 2.048 Mbit/s interface to the other equipment.

A suitable large number of reference inputs (STM-N) should be available to such a node in order to ensure that the SEC node almost never loses all references.

The configuration with SSU shall be considered as an alternative.

8 SYNCHRONIZING THE SDH/PDH TRAFFIC NETWORKS

The synchronization network is a network to provide SDH/PDH traffic networks with reference timing signals.

As recommended before the separate networks are synchronized mainly in the regional level, i.e. the network elements of the separate networks are synchronized from the nearest synchronization network nodes.

The possible signals for synchronizing the equipment, which are co-located with the node clock, are usually 2.048 MHz or 2.048 Mbit/s clock signals. However some equipment may not have dedicated 2.048 MHz or 2.048 Mbit/s inputs for timing and therefore can not be synchronized directly from the node clock. An acceptable alternative is to synchronize such equipment with a synchronous traffic signal e.g. a directly connected 2.048 Mbit/s signal from the co-located digital exchange or an STM-N signal from an SDH NE.

Some equipment at the edge of a network may be situated beyond the reach of the synchronization network. The only practical way to synchronize such equipment is to use a traffic signal e.g. 2.048 Mbit/s signal from a digital exchange. In this case crossing an SDH network has to be accepted.

The distance between the exchange and the equipment to be synchronized is usually small, so that only a single SDH island may be crossed and the probability of TU-12 pointer adjustments is very low. Thus re-timing the 2.048 Mbit/s signal would hardly result in better network performance but might be the solution if problems with longer trails appear.

9 SYNCHRONIZATION IN PACKET NETWORKS

Packet switching was originally introduced to handle asynchronous data. For new applications such as the transport of TDM service and the distribution of synchronization over packet networks, the strict synchronization requirements of those applications must be considered. The ongoing evolution in telecommunications increases the likelihood of hybrid packet/circuit environments for voice and voice band data services. These environments combine packet technologies (e.g., ATM, IP, Ethernet) with traditional TDM systems. Under these conditions, it is critical to ensure that an acceptable level of quality is maintained (e.g. limited slip rate).

In this GFI the different methods to obtain the synchronization related requirements in packet networks are described based mainly on ITU-T Recommendation G.8261.

9.1 TDM timing requirements

The transport of TDM signals through packet networks requires that the signals at the output of the packet network still comply with TDM timing requirements, this is crucial to enable interworking with TDM equipment. These requirements are independent of the type of information (voice or data) transported by the TDM signal.

9.2 Synchronization Network Engineering in Packet Networks

The driving force for much of this work is to cater for the synchronization needs of the application or in general the need of certain technologies (for instance Base Station in GSM and WCDMA networks). In order to achieve such goal, operators have therefore to distribute a reference timing signal of suitable quality to the network elements processing the application or in general requiring accurate timing signal.

9.3 Reference Timing Signal Distribution over Packet Networks

In order to fulfill the applicable synchronization requirements, it should be possible to distribute a reference timing signal with proper phase stability and frequency accuracy characteristics. Two main classes of methods are identified in this recommendation:

- Plesiochronous and Network Synchronous methods
- Packet based methods.

9.3.1 Plesiochronous and Network Synchronous Methods

The first class of methods refers to PRC distributed method (for instance based on GPS), or Master-Slave method using a synchronous physical layer (e.g. STM-N). These methods are widely implemented to synchronize the TDM networks.

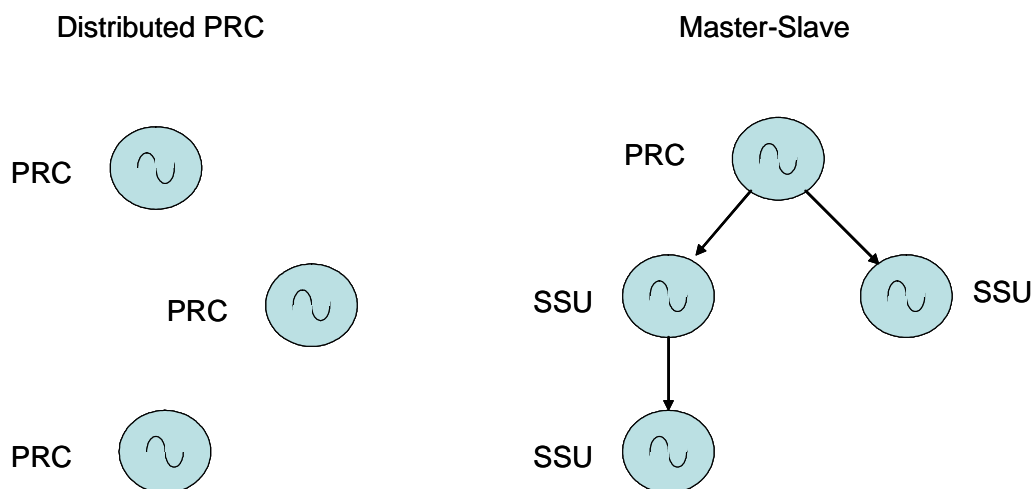

Figure 7. Distributed PRC and Master Slave methods

It has been recognized that when G.811 traceability is required it would be an advantage to be able to distribute timing via a synchronous Ethernet as well as traditional means. It should be noted that there are a number of technical issues to be solved before this technique can be widely used.

According to the text of ITU-T Recommendation G.8261 the general concept of delivering a physical layer clock from the Ethernet switch over the synchronous Ethernet is given in Figure 8.

A reference timing signal traceable to a PRC is injected into the Ethernet switch using an external clock port. This signal is extracted and processed via a synchronisation function before injecting timing onto the Ethernet bit stream. The synchronisation function provides filtering and may require holdover. The clock supporting synchronous Ethernet networks is called EEC, Synchronous Ethernet Equipment Clock (see ITU-T Recc.G.8262).

As shown in the figure there may be a number of Ethernet switches involved in the distribution of the reference timing signal. In such cases the synchronisation function within these Ethernet switches must be able to recover synchronisation “line timing” from the incoming bit stream.

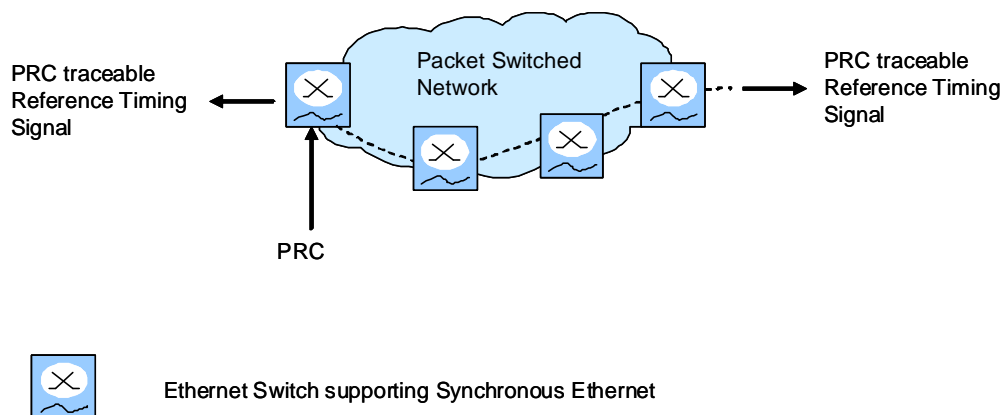

Figure 8 – Example of Master Slave synchronization network over synchronous Ethernet

As part of the architecture a distinction should be made between the network clock and the service clock as described below.

The term synchronous Ethernet applies to the Network Clock, that is the clock that is controlling the bit rate leaving the Ethernet switch. This clock shall comply with ITU-T Recommendation G.8262.

Within existing Ethernet technology the service is effectively asynchronous. In synchronous Ethernet existing Ethernet services will continue to be mapped into and out of the Ethernet physical layer at the appropriate rates as generated by the Service Clocks.

9.3.2 Packet based Methods

The second class of methods relies on timing information carried by the packets (e.g. sending dedicated Time Stamp messages; methods using two-way transfer of timing information are also possible such as NTP or similar protocols; it should be noted that two-way protocols can transport time information as well). In some cases this is the only alternative to a PRC distributed approach.

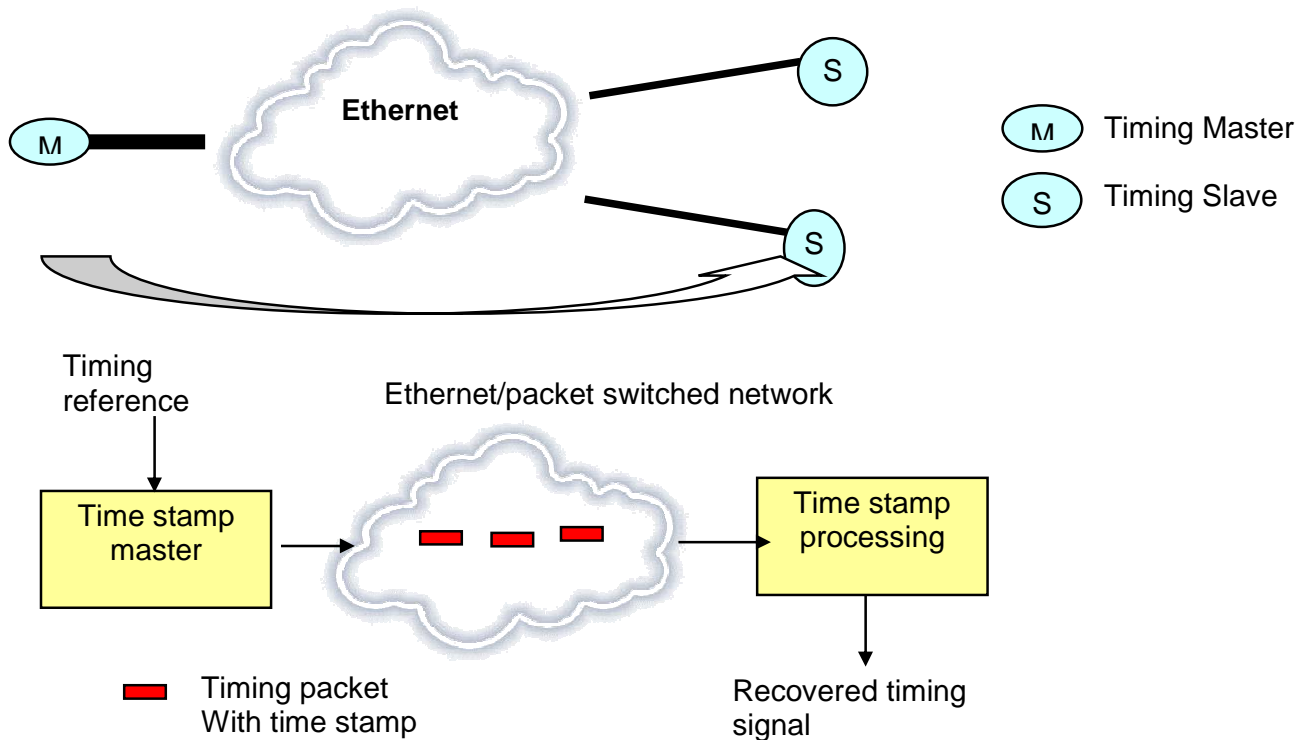

Figure 9. Timing over Packet (ToP) concept

9.4 Timing Recovery for Constant Bit Rate services transported over Packet Networks

CBR (Constant Bit Rate) services (e.g. Circuit Emulated TDM signal) require that the timing of the signal is similar on both ends of the packet network; this is handled by the IWF responsible for delivering the constant bit rate stream. The notion of service clock preservation is that the incoming service clock frequency be replicated as the outgoing service clock frequency when considered in terms of a long-term average. It does not imply that wander on the incoming TDM signal be replicated on the outgoing TDM signal.

Alternative 1 Network - Synchronous Operation

The fully network-synchronous operation use a PRC traceable network derived clock or a local PRC (e.g. GPS) as the service clock. The method does not preserve the service timing.

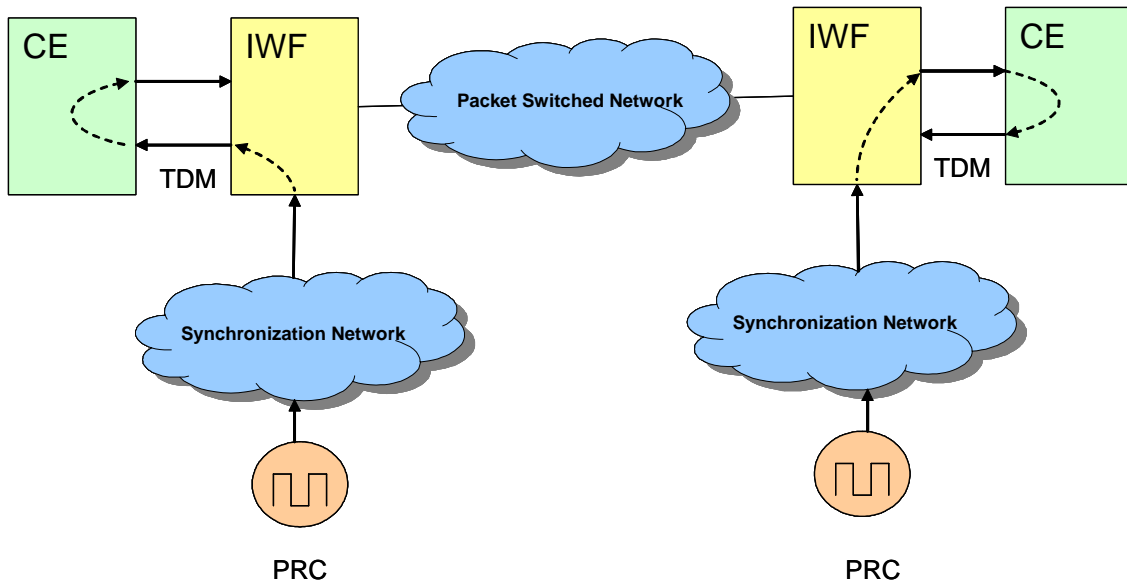

Figure 10. Network Synchronous Operation

Alternative 2 Differential Methods

The difference between the service clock and the reference clock is encoded and transmitted across the packet network. The service clock is recovered on the far end of the packet network making use of a common reference clock. The SRTS (Synchronous Residual Time Stamp) is an example of this family of methods. The method can preserve the service timing.

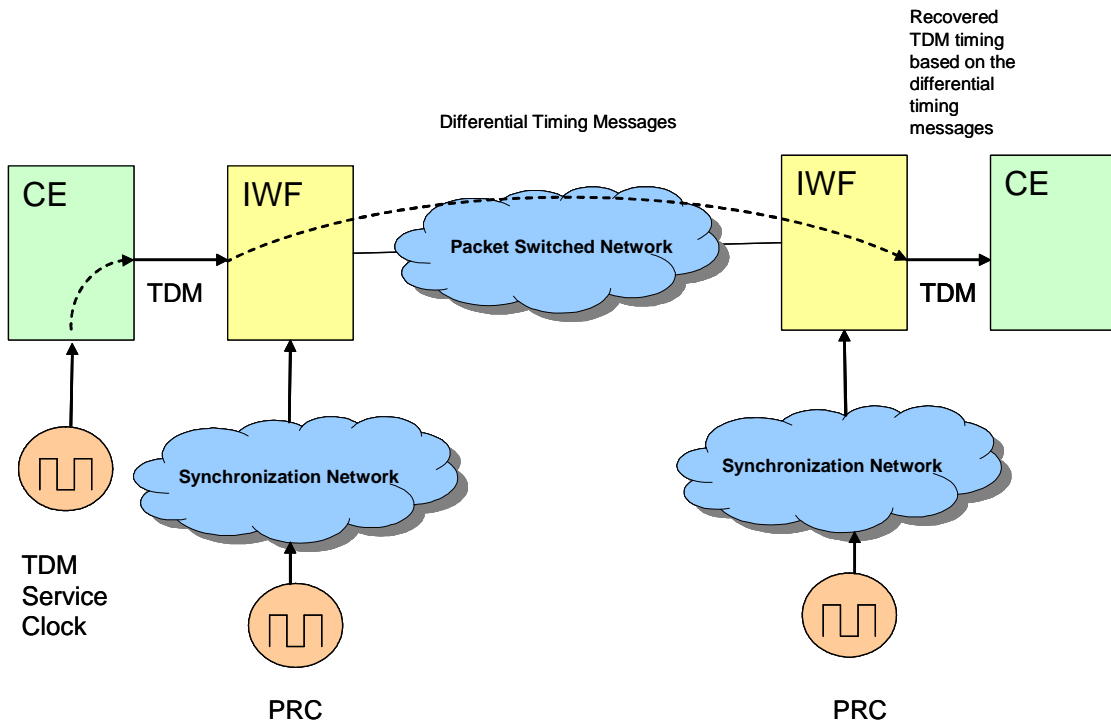

Figure 11. Timing Recovery operation based on Differential Methods

Alternative 3 Adaptive Methods

The timing can be recovered based on the inter-arrival time of the packets or on the fill level of the jitter buffer. The method preserves the service timing.

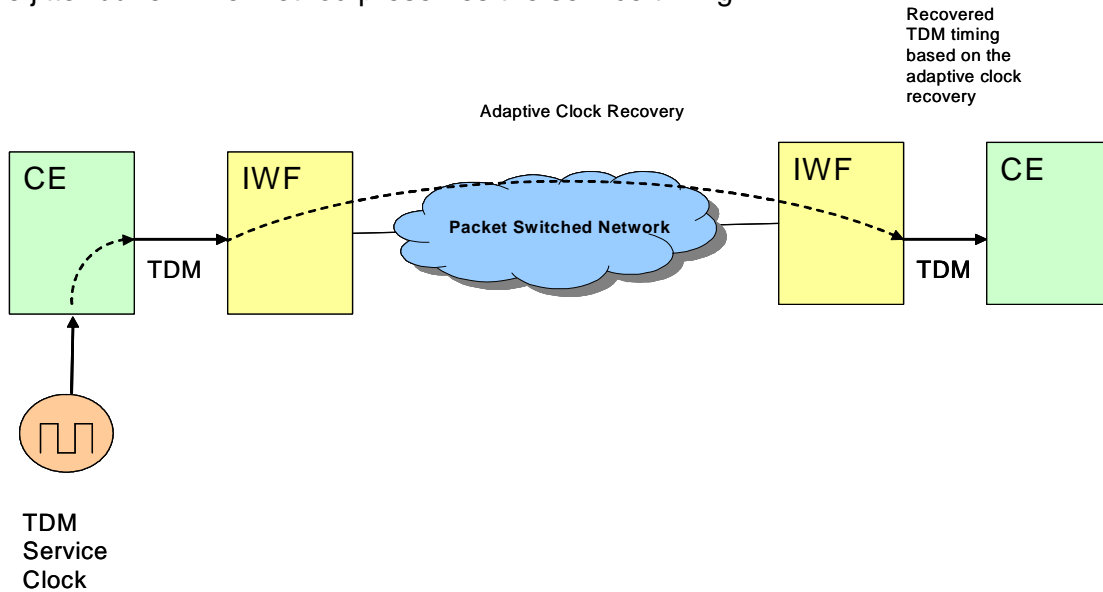

Figure 12. Adaptive Method

Alternative 4 Reference Clock available at the TDM end systems

Both the end systems have direct access to the timing reference, and will retime the signal leaving the IWF. Therefore there is no need to recover the timing. The use of loop timing in the IWF on the TDM interface is an example of the implementation of this method. An example when this scenario might apply is when two PSTN domains are connected via a packet network.

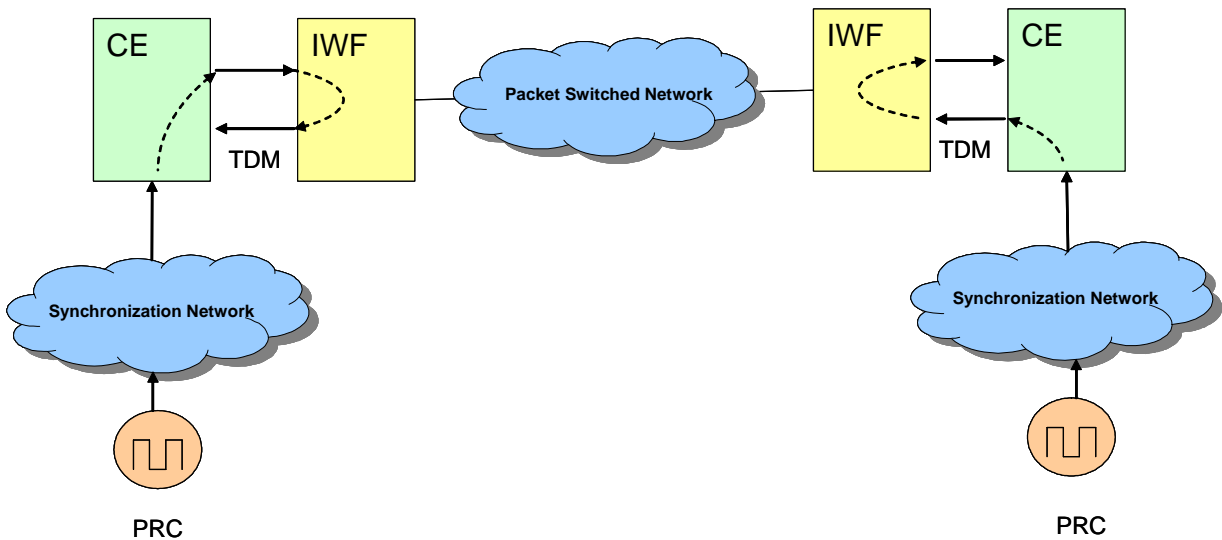

Figure 13. PRC reference timing signal available at the TDM end systems

9.5 Recommendations for the synchronisation in packet networks

The requirements on synchronization functions in packet networks, especially on the boundary of the packet networks, are dependent on the services carried over the network. For TDM based services, the IWF may require network-synchronous operation in order to provide acceptable performance. That's why network-synchronous method is the most recommended timing recovery alternative.

In some cases the adaptive methods might be the only reasonable timing recovery solution. In that case the delay variation in the packet network should be controlled. The acceptable performance depends on the specific service.

The acceptable performance requirements in case of packet based CES islands are defined in three separate deployment cases in the ITU-T Recommendation G.8261 Clause 9 and Appendix IV.

10 TIME/PHASE SYNCHRONIZATION IN PACKET NETWORKS

Phase synchronization is often needed to support requirements for the air interface of some mobile systems, as in the case of TDD systems (for instance, LTE TDD) or when supporting multimedia broadcast/multicast service (MBMS).

Ordinary WCDMA MBMS does not require accurate phase synchronization, since it has been specified and designed to work properly in networks that satisfy the 50ppb frequency accuracy requirement. This requirement, which is guaranteed by the WCDMA node synchronization function (see 3GPP TS 25.402), limits phase drift to between 10 and 20ms.

But when MBMS is based on single-frequency network (MBSFN) mode, timing must be accurate to within a few microseconds. This is because identical waveforms are transmitted simultaneously from multiple cells. The signals from these cells are then combined as the multipath components of a single cell. Terminals must thus perceive the signals of an entire group of transmitting cells as though they came from a single cell. Therefore, all transmissions must be very tightly synchronized and deliver exactly the same content to each base station.

When the radio access in the UMTS mobile system is based on UTRA-TDD (for instance, TD-CDMA, TD-SCDMA) the timing between base stations must be accurate to within $3\mu\text{s}$ (see 3GPP TR 25.836 where the requirement is specified in terms of the maximum deviation in frame start times between any pair of cells that have overlapping coverage areas).

Similar requirements apply to LTE-TDD systems. However by putting some limitations on the deployment (for instance, cell range, isolation) and radio frame configuration, one can define LTE TDD systems to operate with phase accuracy to within tens of microseconds.

In ITU-T several recommendations covering time/phase synchronization in packet networks are in preparation. Those recommendations are:

G.8271 - Time and phase synchronization Aspects of Packet Networks
new recommendation, scheduled for 12/2011

G.8271.1 – Network requirements for transport of phase and time

new recommendation, scheduled for 12/2011

G.8272 – Timing characteristics of Primary Reference Time Clock
new recommendation, scheduled for 12/2011

G.8273 – Framework of Phase and Time Clocks
new recommendation, scheduled for 09/2012

G.8273.1 – Timing Characteristics of Packet Master Clocks
new recommendation, scheduled for 09/2012

G.8273.2 – Timing Characteristics of Telecom Boundary Clocks
new recommendation, scheduled for 09/2012

G.8275 – Time and phase distribution through packet networks
new recommendation, scheduled for 09/2012

G.8275.1 – Precision Time Protocol Telecom Profile for Time/Phase Synchronization
new recommendation, scheduled for 09/2012

This GFI will be updated when the standardisation work in ITU-T has been advanced.